

## 2/2-way valves DN 8 to DN 50

For neutral gases and liquids

Indirectly solenoid actuated

Diaphragm valves

Internal threads G 1/4 to G 2 or 1/4 NPT to 2 NPT

Operating pressure 0.1 to 10 / 16 bar

82400

82410

**Click-on®**



### Description (standard valve)

Solenoid valve for e. g. air, water

Switching function:	normally closed
Flow direction:	determined
Differential pressure:	0.1 bar required (0.3 bar for EPDM)
Fluid temperature:	-10 °C to max. +90 °C
Ambient temperature:	-10 °C to max. +50 °C
Mounting position:	optional, preferably solenoid vertical on top

### Material

Body:	Brass (CW617N)
Seat seal:	NBR
Internal parts:	Stainless steel, PVDF

For contaminated fluids insertion of a strainer is recommended.

### Features

- High flow rate
- Damped operation
- Functional compact design
- Solenoid interchangeable without tools (**Click-on®**)
- Particularly suitable as a water valve according to DIN EN 60730-2-8

EC type examination up to DN 25  
acc. to DIN EN 60730-2-8  
Solenoid Valves  
Test laboratory  
TÜV Rheinland / Brandenburg

### Symbol

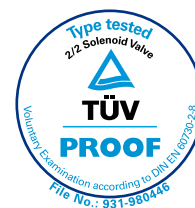
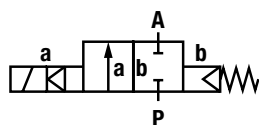

### Ordering information

To order, quote model number from table overleaf, e. g. 8240400.9101 for a DN 25 valve.

## Characteristic Data

### Valves

Part Number with == or ~ solenoid	Nominal Diameter (mm)	Connection Size	Valve Length (mm)	Operating Pressure *		k <sub>v</sub> -value ** (Base m <sup>3</sup> /h)	Weight Total (kg)
				min. (bar)	max. (bar)		
8240000.9101 8241000.9101	8	G 1/4 1/4 NPT	60	0.1	16	1.9	0.47
8240100.9101 8241100.9101	10	G 3/8 3/8 NPT	60	0.1	16	3.0	0.45
8240200.9101 8241200.9101	12	G 1/2 1/2 NPT	67	0.1	16	3.8	0.50
8240300.9101 8241300.9101	20	G 3/4 3/4 NPT	80	0.1	16	6.1	0.65
8240400.9101 8241400.9101	25	G 1 1 NPT	95	0.1	16	9.5	0.95
8240500.9101 8241500.9101	32	G 1 1/4 1 1/4 NPT	132	0.1	10 (16***)	23.0	2.73
8240600.9101 8241600.9101	40	G 1 1/2 1 1/2 NPT	132	0.1	10 (16***)	25.0	2.53
8240700.9101 8241700.9101	50	G 2 2 NPT	160	0.1	10 (16***)	41.0	3.85

\* for gases and liquid fluids up to 25 mm<sup>2</sup>/s (cSt)

State voltage [V] and frequency [Hz]

\*\* C<sub>v</sub>-value (US) ≈ k<sub>v</sub>-value x 1.2

\*\*\* with solenoid 9151

## Solenoid 9101 / 9151

### Standard voltages

DC ==	AC ~ 50 Hz	AC ~ 60 Hz
24 V	24 V	–
–	110 V	120 V
–	230 V	220 V

Design acc. to DIN VDE 0580

Voltage range ±10 %

100 % duty cycle

Protection class acc. to EN 60529 IP65

Socket Form A acc. to DIN EN 175301-803 (included)

## Power Consumption

According to DIN VDE 0580 at coil temperature of +20 °C. In operation the power consumption of the solenoid decreases by approx. 30 %.

Solenoid	DC ==	AC ~	
		Inrush	Holding
9101 *	8 W	15 VA	12 VA / 7 W
9151 *	18 W	45 VA	35 VA / 17 W

\*  coil only

### Attention!

The conditions imposed on the Ex approvals lead to reduction of the permissible standard temperature ranges in the cases of explosion protected solenoids.

## Further Options (Valves)

- XXXXX01.XXXX Normally open (NO),  
from G 1 1/4 with solenoid 9151,  
0.1 up to 16 bar
- XXXXX02.XXXX Manual override
- XXXXX03.XXXX Seat seal FPM,  
max. fluid temperature –5 °C up to +110 °C
- XXXXX14.XXXX Seat seal EPDM, for hot water,  
max. fluid temperature +110 °C,  
0.3 to 16 bar up to DN 25  
0.3 to 10 bar from DN 32
- XXXXX50.XXXX Latching system,  
impulse time min. 30 ms,  
only for DC 6 V, 12 V and 24 V
- On request Further versions

## Further Options (Solenoids)

- XXXXXXXX.9136 Solenoid in protection class  
 II 2 GD EEx m II T4 T 110 °C  
with 3 m connection cable
- On request Further versions

## Section View

to G 1 e. g. 1 NPT

- 101 Valve body
- 102 Valve cover
- \*103 Diaphragm
- 104 Allen head screw
- \*105 Pressure spring
- 400 Solenoid
- 701 Core tube
- \*702 O-ring
- 703 Screw piece
- \*704 Pressure spring
- \*705 Plunger
- 706 Spring clip
- \*707 O-ring
- 1400 Electrical connector (included)

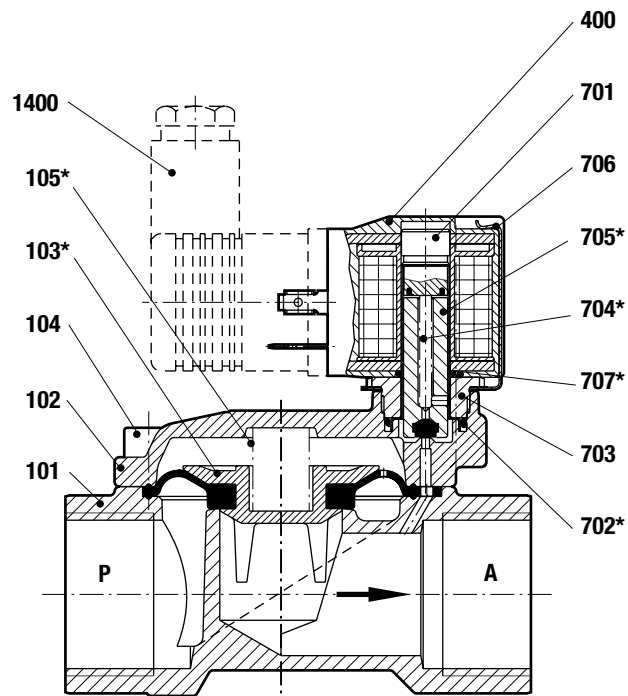

up to G 1 1/4 e. g. 1 1/4 NPT

- 101 Valve body
- 102 Valve cover
- \*103 Diaphragm
- 104 Allen head screw
- \*105 Pressure spring
- 400 Solenoid
- 701 Core tube
- \*702 O-ring
- 703 Screw piece
- \*704 Pressure spring
- \*705 Plunger
- 706 Spring clip
- \*707 O-ring
- 1400 Electrical connector (included)

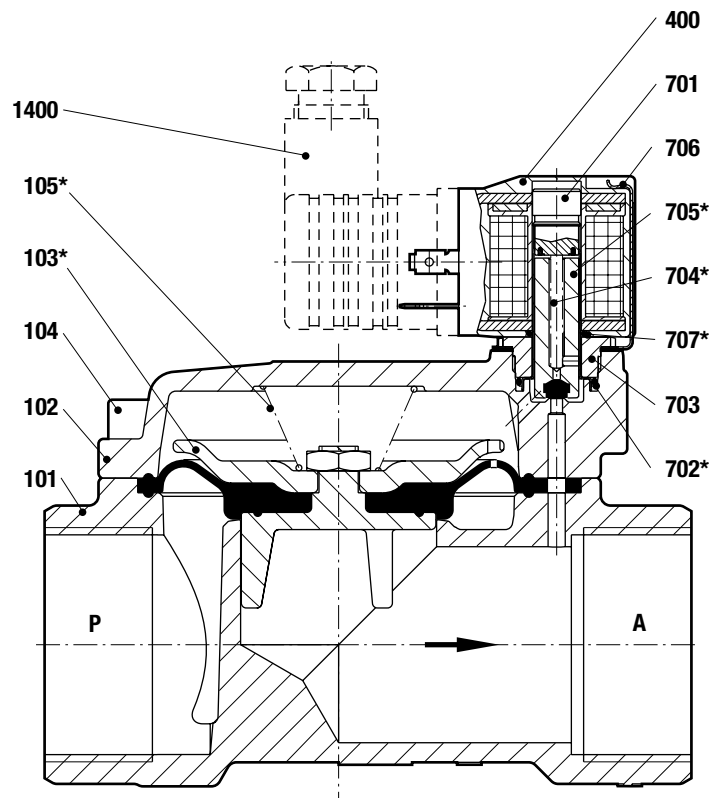

\* These individual parts form a complete wearing unit.  
When ordering spare parts please state Cat. No. and Series No.

**General Dimensions**

Solenoid rotatable 360°  
 Socket turnable 4 x 90°  
 (Socket included)

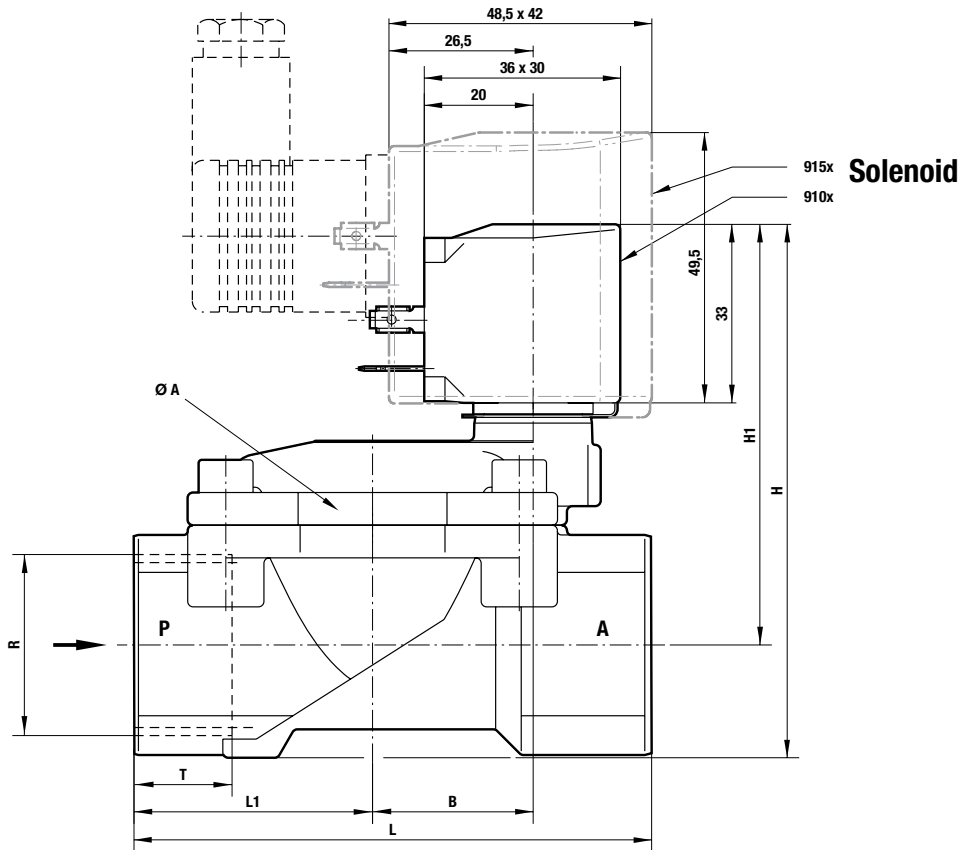

Part Number with --- or ~ solenoid	Nominal Diameter (mm)	Connection Size	Ø A (mm)	B (mm)	H (mm)	H1 (mm)	L (mm)	L1 (mm)	T (mm)
8240000.9101 8241000.9101	8	G 1/4 1/4 NPT	44	19.5	78.5	67.0	60	27.5	12.0 10.0
8240100.9101 8241100.9101	10	G 3/8 3/8 NPT	44	19.5	78.5	67.0	60	27.5	12.0 10.5
8240200.9101 8241200.9101	12	G 1/2 1/2 NPT	44	19.5	81.0	67.0	67	31.0	14.0 13.5
8240300.9101 8241300.9101	20	G 3/4 3/4 NPT	50	24.0	88.0	71.5	80	36.5	16.0 14.0
8240400.9101 8241400.9101	25	G 1 1 NPT	62	29.5	97.5	77.0	95	44.0	18.0 17.0
8240500.9101 8241500.9101	32	G 1 1/4 1 1/4 NPT	92	44.5	124.5	95.5	132	60.0	20.0 17.0
8240600.9101 8241600.9101	40	G 1 1/2 1 1/2 NPT	92	44.5	124.5	95.5	132	60.0	22.0 17.0
8240700.9101 8241700.9101	50	G 2 2 NPT	109	54.5	142.5	108.0	160	74.0	24.0 17.5

**Note to Pressure Equipment Directive (PED):**

The valves of this series, including the connection size DN 25 (G 1), are according to Art. 3 § 3 of the Pressure Equipment Directive (PED) 97/23/EG. This means interpretation and production are in accordance to engineers practice wellknown in the member countries.

The CE-sign at the valve refers not to the PED. Thus the declaration of conformity is not longer applicable for this directive.

For valves > DN 25 (G 1) Art. 3 § (1) No.1.4 applies.

The basic requirements of the Enclosure I of the PED must be fulfilled. The CE-sign at the valve includes the PED. A certificate of conformity of this directive will be available on request.

**Note to Electromagnetic Compatibility Guideline (EEC):**

The valves shall be provided with an electrical circuit which ensures the limits of the harmonised standards EN 61000-6-3 and EN 61000-6-1 are observed, and hence the requirements of the Electromagnetic Compatibility Guideline (2004/108/EG) satisfied.